

BALL VALVES RK-PROBALL

KH 2T F-FS, DN15 - DN100, PN16/40

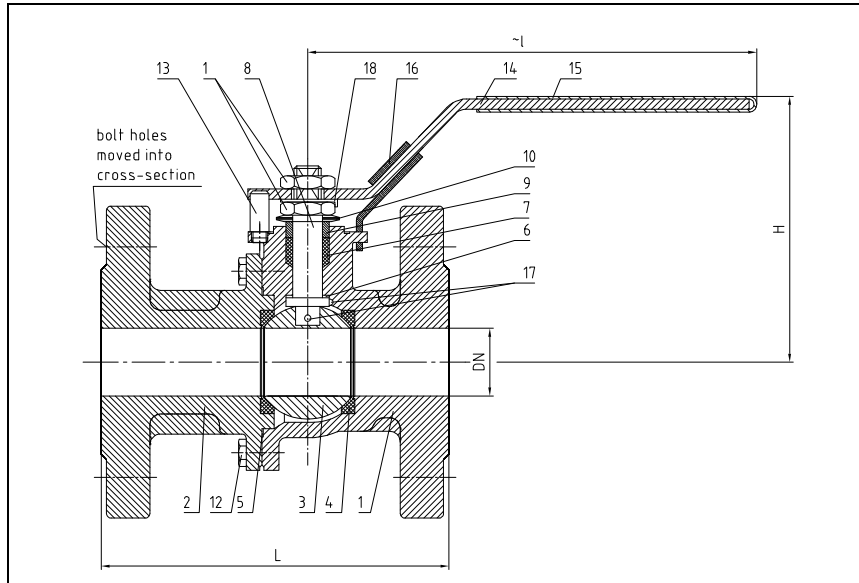

Ball valves RK-Probball KH 2T F of all sizes are also available with pneumatical, electrical or hydraulic actuators.

No.	Part	Material	Material
1	body	1.0619	1.4408
2	cap	1.0619	1.4408
3	ball	1.4408	
4	seat	KFM	
5	seal	Graphite	
6	thrust washer	KFCM	
7	stem packing	Graphite	
8	stem	1.4401	
9	ring	1.4401	
10	belleville washer	1.4310	
11	nut	1.4301	
12	screw	A4-70	
12.1	stud bolt, GR.27	A4-70	
12.2	nut, GR.27	A4-70	
13	stop pin	1.4301	
14	lever	1.4301	
15	insulation cover	Vinyl	
16	spring locking device*	1.4301	
17	antistatic element	1.4401	
18	locking washer	1.4301	

* special type

Dimensions

DN mm	DN Zoll	PN	dimensions (mm)				top flange ISO	torque Nm**	weight	
			H	I	L GR.1	L GR.27			kg GR.1	kg GR.27
15	1/2"	40	86	165	130	115	F04	6	2.4	2.3
20	3/4"	40	92	165	150	120	F04	10	3.2	3.1
25	1"	40	106	176	160	125	F05	14	4.6	4.3
32	1 1/4"	40	114	215	180	130	F05	22	6.5	6.0
40	1 1/2"	40	116	215	200	140	F05	30	7.5	7.0
50	2"	40	136	278	230	150	F07	41	12.3	11.4
65	2 1/2"	40	150	278	290	170	F07	65	17.0	15.2
65	2 1/2"	16	150	278	290	170	F07	65	15.7	14.1
80	3"	40	185	375	310	180	F10	94	24.1	22.0
80	3"	16	185	375	310	180	F10	94	22.9	20.5
100	4"	40	200	375	350	190	F10	130	32.9	29.8
100	4"	16	200	375	350	190	F10	130	30.0	26.2

**Necessary torque measured with treated water at Δ P acc. to pressure 16 bar and room temperature

Flanged ball valve
full bore
face to face acc. to 558, GR.1
face to face acc. to 558, GR.27
flanges acc. to EN 1092

Specification:

Two-piece ball valve, flanges acc. to EN 1092, face to face dimensions acc. to EN 558, GR.1/GR.27, full bore, blow-out-proof stem, body material stainless steel (1.4408) or steel (1.0619), antistatic device, free of non ferrous metals, seat KFM, stem packing graphite, disc spring loaded adjustable, top flange DIN EN ISO 5211, approved by PED, certified acc. to GERMAN clean air act VDI 2440, Fire-Safe acc. to API 607, safety spring locking device is optional.

Marking: RK-Probball

Types: KH 2T F-FS-1.0619

KH 2T F-FS-1.4408

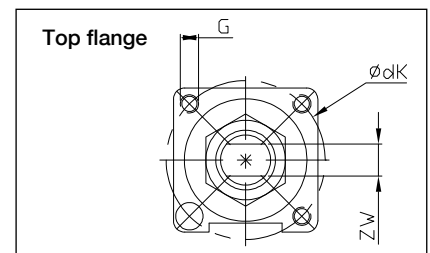

DN (mm)	Ø dk	G	ZW
15	42 x	M 5 x 0.8	8
20	42 x	M 5 x 0.8	8
25	50 x	M 6 x 1.0	10
32	50 x	M 6 x 1.0	10
40	50 x	M 6 x 1.0	10
50	70 x	M 8 x 1.25	14
65	70 x	M 8 x 1.25	14
80	102 x	M 10 x 1.5	19
100	102 x	M 10 x 1.5	19

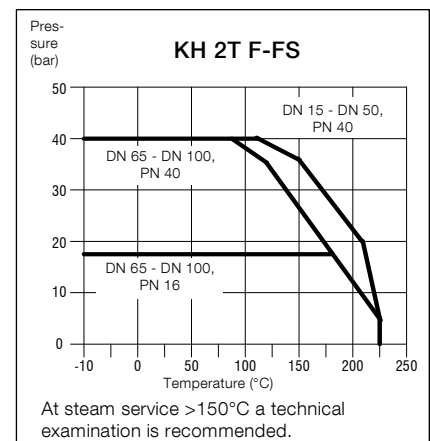

Ordering example:
KH 2T F-FS, DN 65, PN 16, GR.1, 1.4408,
safety spring locking device